

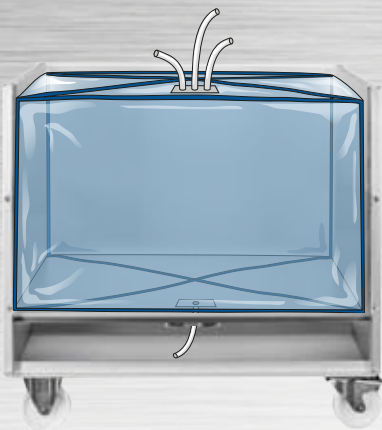

**storing, shipping &
protecting bulk liquids
in single-use bags**

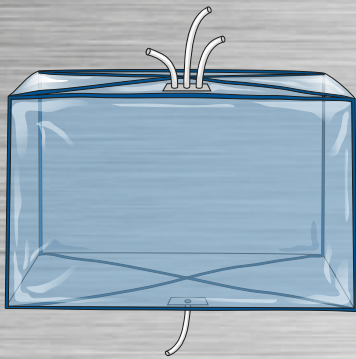

bagtainer® – storing and shipping bulk liquids in single-use bags

Single-use systems are increasingly important in bioprocessing. The combination of sterile, pharma-compliant, single-use plastic bags up to 5000 litres and suitable storage and transport containers (bagtainers®) has revolutionized the handling of bulk liquids in bioprocessing.

We specialize in customized manufacturing of stainless steel bagtainers® for any kind of application (storing, shipping, protecting bulk liquids). And all kinds of stainless steel products related to single-use systems.

We provide:

- shipping bagtainers®
- holding / storage bagtainers®
 - processing bagtainers® with
 - jacketed walls (heatable / coolable)
 - mixing devices
 - weighing devices
 - stirring devices
- collapsible bagtainers®
- bagtainers® for dangerous goods
- dollies & trolleys (accessories)
- additional process equipment
- competitive price performance ratio

Qualified according to ISO 9001:2015, DIN EN ISO 3834, DIN EN 1090



compatibility – bagtainers® can be adapted to every bag format and to all brands available on the market

- all formats and volumes, from 1 to 5000 litres
- 2D and 3D bioprocessing bags
- matching bag port positions (filling, draining, processing)





made of stainless steel

Just as armor protects a knight, stainless steel bagtainers® protect your valuable liquids.

Stainless steel provides several advantages:

- premium product quality
- extreme long life / durability
- cleanroom compliant
- autoclavable
- superior surface quality – no adhesion with bag material
- flexible and economical customization

Long-term experience and continuous control ensures the long-lasting quality and reliability of our bagtainers®.

Trust in the protection of your valuable goods through our certified products Made in Germany.

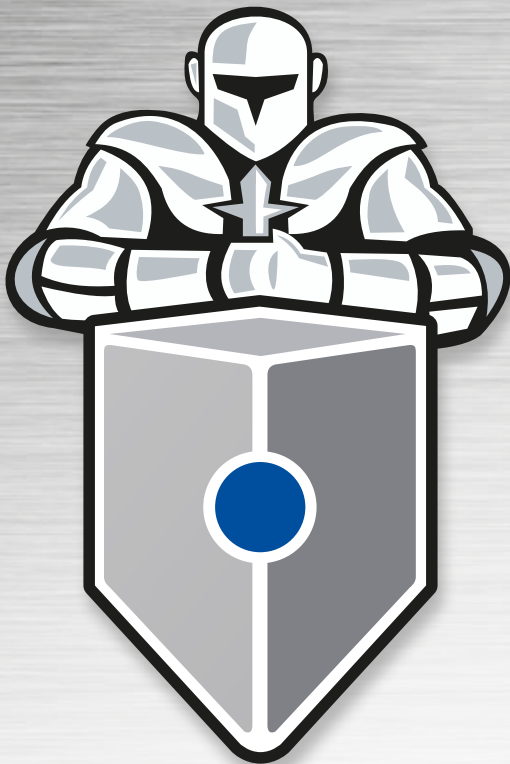



shipping bagtainers® – trouble-free moving and shipping

Shipping bagtainers® prevent the bag from being ripped during transport. The unique bagtainer® bag securing system is easy to operate and allows for underfilling the bag down to any level, still securing the liquid during transport.

- every required volume up to 1000 litres
- unique bagtainer® bag securing system which works with intermediate volumes
- can easily be moved by forklift or with use of other accessories
- stackable empty or filled
- cabinet for tubing and sample bags
- collapsible alternatives available

Upon customer request, we can coordinate testing according to ISTA / ASTM standards. Testing will always be performed with the combination of bagtainer® and your specific (branded) bag. Performance testing includes atmospheric conditioning, random vibration, and shock testing.

Some liquids (such as sodium hydroxide or ethanol) require particular certification for hazardous materials (UN) – please enquire.



bagtainer® bag securing system



200 litres shipping bagtainer®
with bagtainer® bag securing system



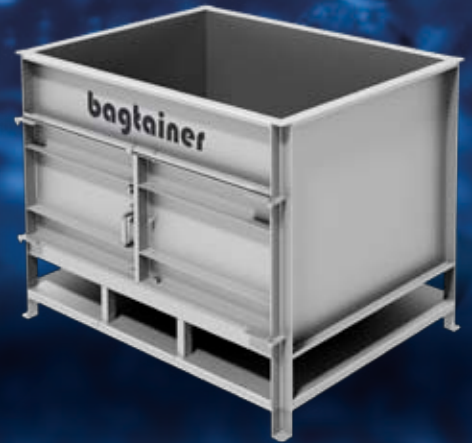

modular 3000 litres bagtainer®
pickled & passivated surface



3000 litres bagtainer® brushed surface

storing bagtainers® – reliable and convenient inhouse solutions

Storing bagtainers® are commonly used to store, move or process bulk liquids on-site. Unlimited customizability allows for any accessory to be added.

- volumes from 1 to 5000 litres
- temperature controlling devices (jacketed walls)
- stirring & circulation devices
- weighing or fill monitoring systems
- deployment support for bags / hoist system
- moving equipment
- interface to monitoring systems

If you need special accessories for your application, please contact our engineering team!



2000 litres coolable / heatable
bagtainer® brushed surface



unlimited customizing options

- matching customized bag formats
- matching individual bag port positions
- different surface options (pickled & passivated, brushed, electropolished)
- customized branding / labelling
- stackability (empty and filled)
- different castor wheel materials
- collapsible alternatives
- moving equipment (dollies, trolleys, couplings)
- doors, flaps & lids
- windows & slots
- tube cabinets

If you still have an uncovered requirement – please contact us.



doors & windows



weighing system



hose flap



master mover coupling



hoist system

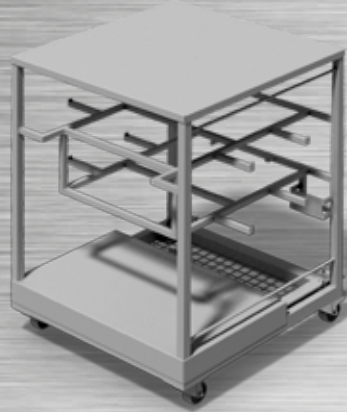
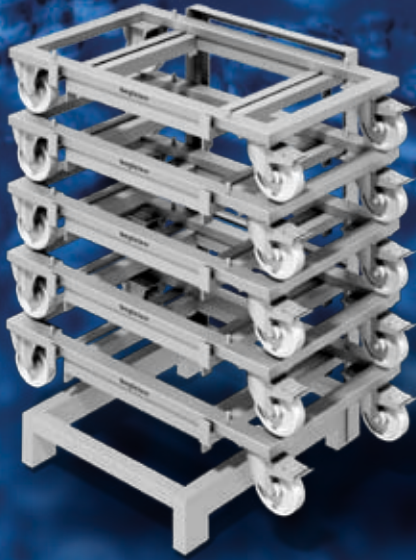

additional process equipment related to single-use technology

All kinds of stainless steel process equipment can be designed and manufactured for your needs.

For example:

- frames for process components
- laboratory benches
- cooling & heating plates
- dollies & trolleys

We look forward to your enquiries!



manufactured for your needs

The individual and easy-to-use solutions to your problems and requirements are our focus. We take pride in short time to market based upon our solution-oriented engineering and single piece to large quantity production.

Schulte bagtainer® systems GmbH is certified according to ISO 9001:2015, DIN EN ISO 3834 and DIN EN 1090.

The production of bagtainers® is based upon high-precision laser-cut parts. Mechanical processing and welding is done by qualified personnel. All products are surface finished (pickled & passivated, brushed, electropolished) before getting assembled prior to being shipped.

The strong quality assurance guarantees that bagtainers® meet your specifications. Audits of our company are always welcome.



modular 2000 litres bagtainer®
pickled & passivated surface



construction experience

As a result of more than 15 years of specialization in stainless steel construction and manufacturing, Schulte bagtainer® systems GmbH is a top provider of bag holding and bioprocessing equipment.

All products are custom-made with major input from bioprofessionals.

We also supply:

- state of the art 3D design
- on-site consultancy
- integration with on-site engineering
- proprietary designs (branded designs)
- interface with application equipment (temperature control, stirring, weighing,...)

We look forward to your enquiries!

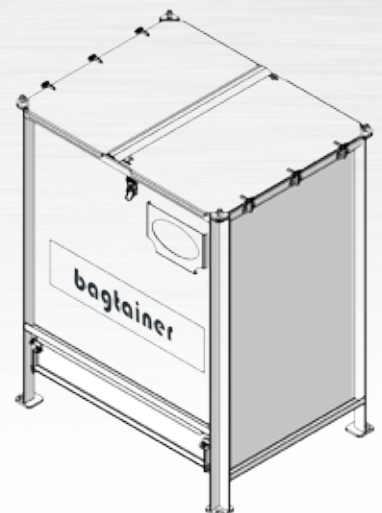
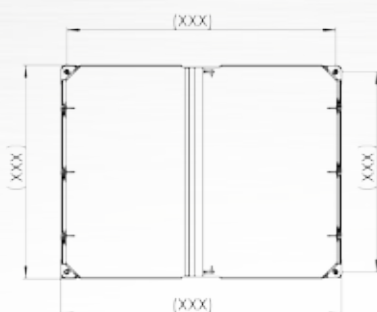



your contact to bagtainer®



Darmcher Grund 16
58540 Meinerzhagen
Germany

phone: +49 2354 -77841-0
mail: info@bagtainer.com

Scan the QR code for an instant
link to [Google Maps](#).



gestaltung: www.die-gestalter.de

Schulte bagtainer[®] systems GmbH

Darmcher Grund 16
58540 Meinerzhagen
Germany

phone: +49 2354 -77841-0
mail: info@bagtainer.com

bagtainer.com

