

Società Italiana Viterie e Minuterie

S.I.V.E.M. S.n.c.



Our Company

S.I.V.E.M. was born in 1963 in Busalla (Genoa) further to a twenty-year of experience in the screw sector, specialised in standard brass screws.

After lots of progress, in 1997 our company set up with a new production under good guidance of BISIO' s family.

From the technical and commercial growth of our company and the widening of the screws sector, as special cold forming screws, mostly sheared and turned items, it turned out that S.I.V.E.M. was a productive and flexible reality in order to satisfy its customer requirements in a short time, maintaining a competitive commercial setting out .

This philosophy will be pursued in order to guarantee our customers the quality of our products, going always on maintaining and improving the standard production quality.

Recently S.I.V.E.M. has increased its customers maintaining its old historical ones with a wide range of products.

We are able to supply customers as retailer, ironmonger, direct users and screw producers, too.

Moreover we can also draw up a yearly program with a great collaboration to solve out every type of customer problem.

The technology of commerce we supply changes from the electromechanical, electronics, fittings, lightning, food industry, automotive, clamps and wiring, mechanical components production of any type.

S.I.V.E.M. S.r.l.

PRODUCTION





Since 1997 we have maintained the main production setting up the brass screws, of which a wide range is ready in our stock.

Afterwards S.I.V.E.M. achieved a specialisation in production of special items as cold-forming realised according to either a customer drawing or projected in operation of the final product.

S.I.V.E.M. can supply both the standard and not unified screws with a wide range which changes from the diameter 2 mm to 10-12 mm for a length from 2 to 100 mm.

The products can be realised in several materials as follows :

- " Stainless steel AISI 304, AISI 316, AISI 410, AISI 430.
- " Steel for strength classes 4.8, 5.8, 8.8, 10.9, 12.9.
- " Steel for carbonitriding, copper, brass, aluminium

We can also supply products with thermal and superficial treatments carried out from trustworthy certified companies.

We are mainly competitive and reliable for the standard iron, stainless and brass screws.

The standard production is according to the rule DIN, UNI, ISO and international parameters.

In case of detailed request of screws not standard, we use to start up the planning of the equipment and consequent production process.

Moreover we can also develop projects aimed at solving out special requirements, checking the safety rules and offering the customers superior performances to that standard ones.

Production

PRODUCTION

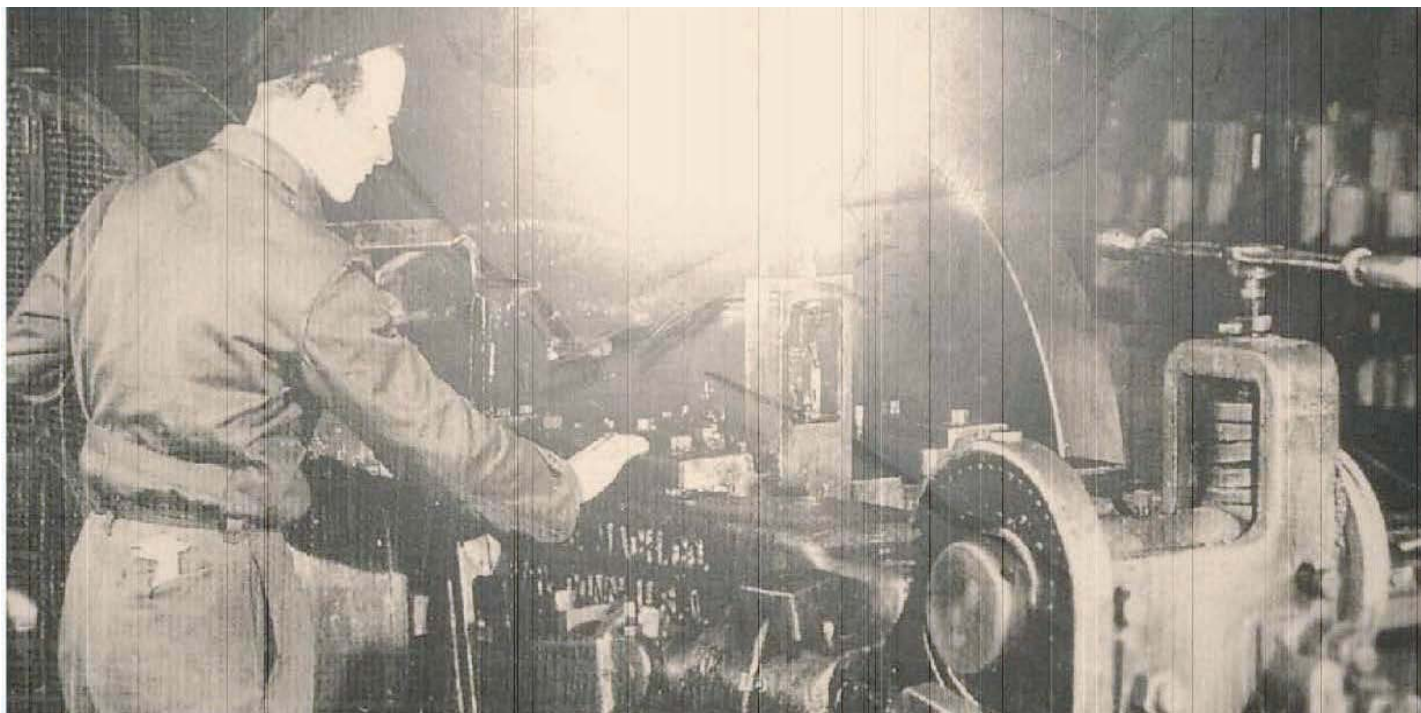

He prints to cold

Threading



PRODUCT



A FEW EXAMPLES OF SCREWS AND SPECIAL MINUTERIA ON DEMAND

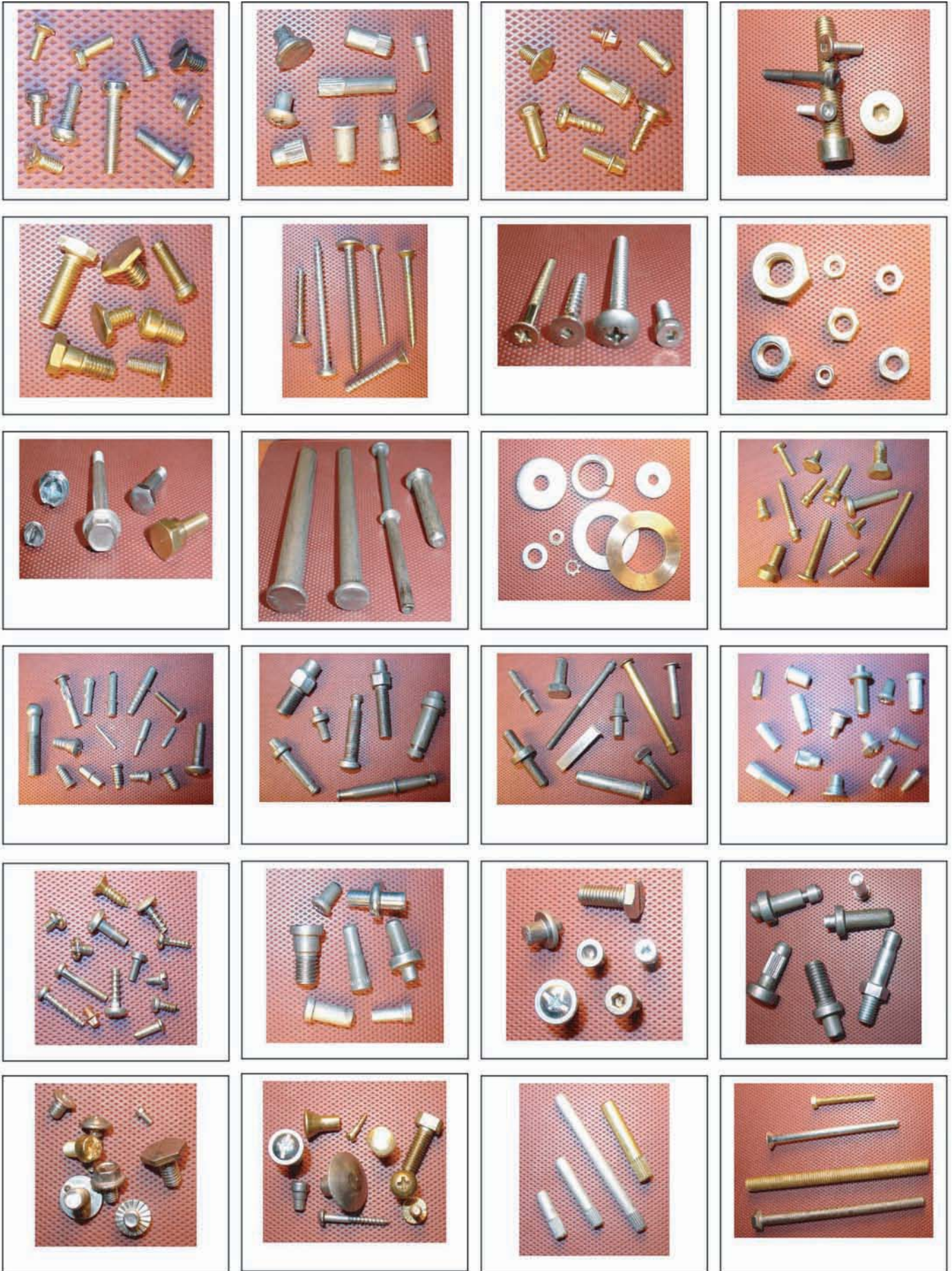

Special bolts to design upon request

STORE



Metrical brass screw store

Our stock management is computerised and it manages the brass screws DIN 84, DIN 963, DIN 933, packed in thermal-welded small bags in a quantity from 50 to 3000 pieces.

(we can do daily mixed forwarding for small quantities, too).

Other type of brass screws are produced by request in a short time.

Our stock personnel provides to order the standard production according to the adequate quantity to face the trend of the demand, valued on our historical sales base.

Thousands of items are stocked with the status: " PROMPT DELIVERY", available to be sent to destination immediately. The delivery time is optimal.

The identification and traceability system of the batches show a remarkable quality service we offer our customers.

Screw brass store



Stainless steel thread store



Part counter weigher



Thread brass store



Packaging



Screw brass price list

DIN 84 - DIN 933 - DIN 963 - DIN 964 available in stock

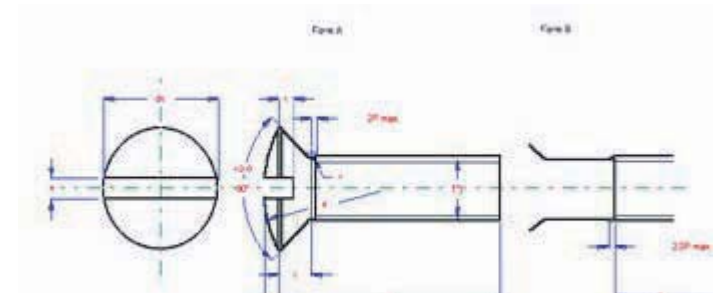
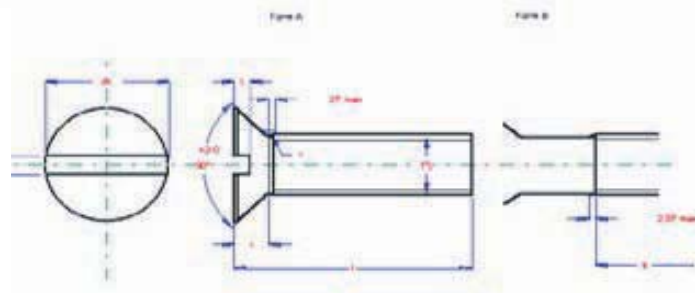
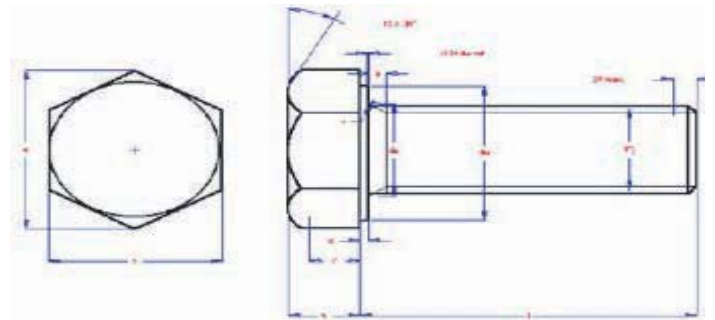
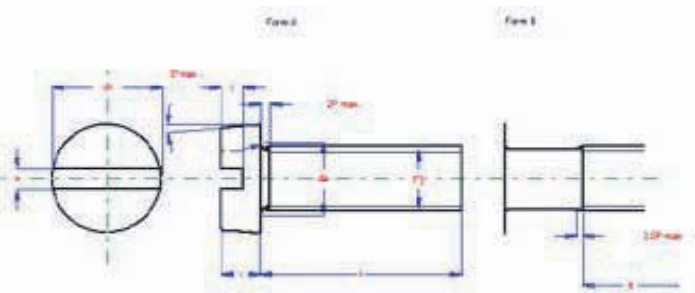

DIN 965 - DIN 966 - DIN 7985 produced on demand

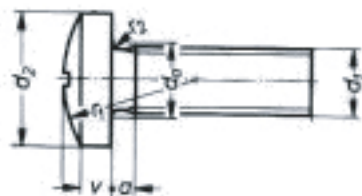
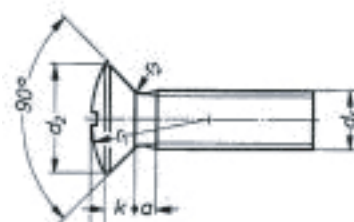
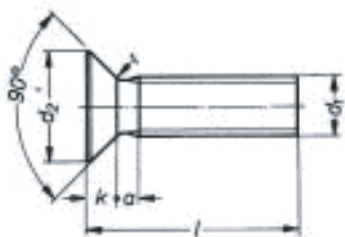

SCREWS OF BRASS FOR METAL

PRINT E ROLLS – THREADING METRICAL ISO BIG STEP

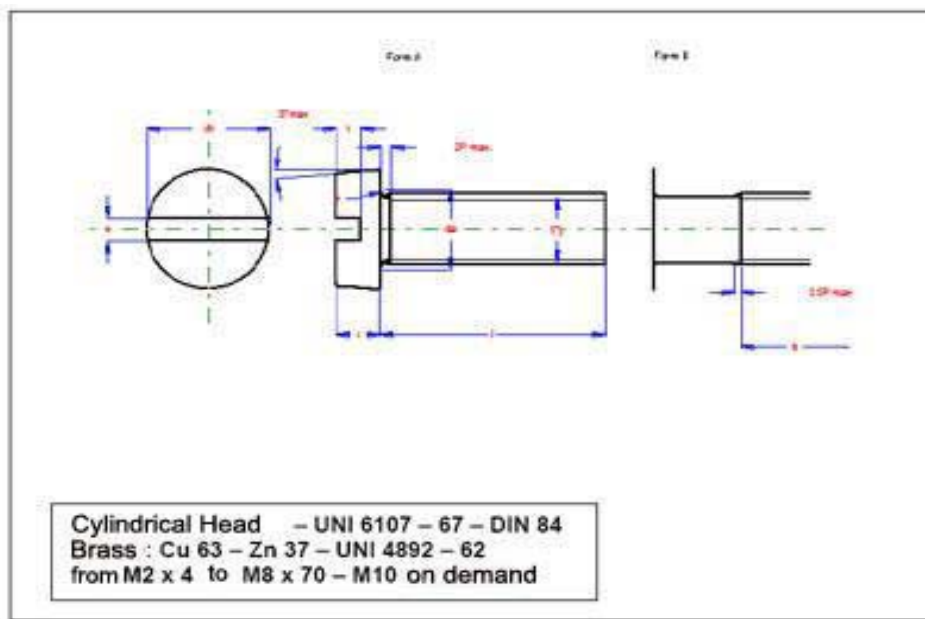

Material Brass Cu 63 – Zn 37 – UNI 4892 - 62

d	M2	M 2,5	M 2,6	M 3	M 4	M 5	M 6	M 8	M 10
dk	3,8	4,5	5	5,5	7	8,5	10	13	16
K	1,3	1,6	1,8	2	2,6	3,3	3,9	5	6
n x t	0,5 x 0,6	0,6 x 0,7	0,6 x 0,9	0,8 x 0,9	1 x 1,2	1,2 x 1,5	1,6 x 1,8	2 x 2,3	2,5 x 2,7

Article Code	Measure in mm.	Individual prices	Wrapping price					
--------------	----------------	-------------------	----------------	--	--	--	--	--

FVIOTTCM2X04	M 2 x 4							
FVIOTTCM2X05	5							
FVIOTTCM2X06	6							
FVIOTTCM2X08	8							
FVIOTTCM2X10	10							
FVIOTTCM2X12	12							
FVIOTTCM2X14	14							
FVIOTTCM2X16	16							
FVIOTTCM2X20	20							
FVIOTTCM2X25	25							
FVIOTTCM2.5X04	M 2,5 x 4							
FVIOTTCM2.5X05	5							
FVIOTTCM2.5X06	6							
FVIOTTCM2.5X08	8							
FVIOTTCM2.5X10	10							
FVIOTTCM2.5X12	12							
FVIOTTCM2.5X14	14							
FVIOTTCM2.5X16	16							
FVIOTTCM2.5X18	18							
FVIOTTCM2.5X20	20							
FVIOTTCM2.5X22 *	22						* only on demand	

Article Code	Measure in mm.	Individual prices	Wrapping price					
FVIOTTCM2.5X25	25							
FVIOTTCM2.5X30	30							
FVIOTTCM3X04	M 3 x 4							
FVIOTTCM3X05	5							
FVIOTTCM3X06	6							
FVIOTTCM3X07	7							
FVIOTTCM3X08	8							
FVIOTTCM3X10	10							
FVIOTTCM3X12	12							
FVIOTTCM3X14	14							
FVIOTTCM3X16	16							
FVIOTTCM3X18	18							
FVIOTTCM3X20	20							
FVIOTTCM3X25	25							
FVIOTTCM3X30	30							
FVIOTTCM3X35	35							
FVIOTTCM3X40	40							
FVIOTTCM3X50	50							
FVIOTTCM3X60	60							
FVIOTTCM4X05	M 4 x 5							
FVIOTTCM4X06	6							
FVIOTTCM4X07	7							
FVIOTTCM4X08	8							
FVIOTTCM4X10	10							
FVIOTTCM4X12	12							
FVIOTTCM4X14	14							
FVIOTTCM4X16	16							
FVIOTTCM4X18	18							
FVIOTTCM4X20	20							
FVIOTTCM4X22 *	22					* only on demand		
FVIOTTCM4X25	25							
FVIOTTCM4X30	30							
FVIOTTCM4X35	35							
FVIOTTCM4X40	40							
FVIOTTCM4X45	45							
FVIOTTCM4X50	50							
FVIOTTCM4X60	60							
FVIOTTCM4X70	70							
FVIOTTCM5X06	M 5 x 6							
FVIOTTCM5X07	7							
FVIOTTCM5X08	8							
FVIOTTCM5X10	10							
FVIOTTCM5X12	12							
FVIOTTCM5X14	14							
FVIOTTCM5X16	16							
FVIOTTCM5X18	18							
FVIOTTCM5X20	20							
FVIOTTCM5X25	25							
FVIOTTCM5X30	30							
FVIOTTCM5X35	35							
FVIOTTCM5X40	40							

Article Code	Measure in mm.	Individual prices	Wrapping price					
FVIOTTCM5X45	45							
FVIOTTCM5X50	50							
FVIOTTCM5X60	60							
FVIOTTCM5X70	70							
FVIOTTCM6X08	M 6 x 8							
FVIOTTCM6X10	10							
FVIOTTCM6X12	12							
FVIOTTCM6X14	14							
FVIOTTCM6X16	16							
FVIOTTCM6X18	18							
FVIOTTCM6X20	20							
FVIOTTCM6X25	25							
FVIOTTCM6X30	30							
FVIOTTCM6X35	35							
FVIOTTCM6X40	40							
FVIOTTCM6X45	45							
FVIOTTCM6X50	50							
FVIOTTCM6X60	60							
FVIOTTCM6X70	70							
FVIOTTCM8X10	M 8 x 10							
FVIOTTCM8X12	12							
FVIOTTCM8X14	14							
FVIOTTCM8X16	16							
FVIOTTCM8X18	18							
FVIOTTCM8X20	20							
FVIOTTCM8X25	25							
FVIOTTCM8X30	30							
FVIOTTCM8X35	35							
FVIOTTCM8X40	40							
FVIOTTCM8X45	45							
FVIOTTCM8X50	50							
FVIOTTCM8X60	60							
FVIOTTCM8X70	70							
FVIOTTCM10X16 *	M 10 x 16					* only on demand		
FVIOTTCM10X20 *	20							
FVIOTTCM10X25 *	25							
FVIOTTCM10X30 *	30							
FVIOTTCM10X35 *	35							
FVIOTTCM10X40 *	40							
FVIOTTCM10X50 *	50							
FVIOTTCM10X60 *	60							
FVIOTTCM10X70 *	70							
FVIOTTCM10X80 *	80							
FVIOTTCM10X90 *	90							

SCREWS OF BRASS FOR METAL
PRINT E ROLLS – THREADING METRICAL ISO BIG STEP

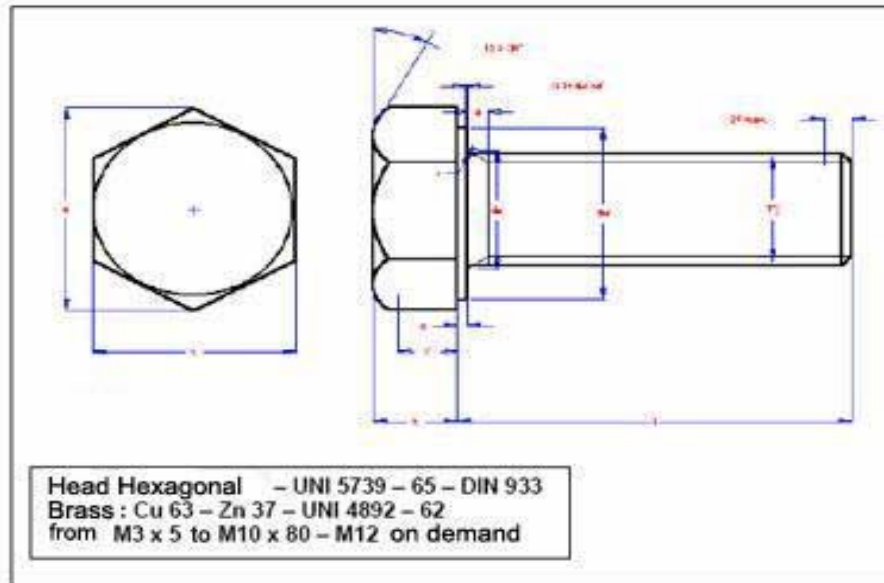

Material Brass Cu 63 – Zn 37 – UNI 4892 - 62

d	M 3	M 4	M 5	M 6	M 8	M 10
S	5,5	7	8	10	13	17
K	2	2.08	3.05	4	5.05	7

Article Code	Measure in mm.	Individual prices	Wrapping price
--------------	----------------	-------------------	----------------

FVIOTTEM3X08	M 3 x 8		
FVIOTTEM3X10	10		
FVIOTTEM3X12	12		
FVIOTTEM3X14	14		
FVIOTTEM3X16	16		
FVIOTTEM3X18	18		
FVIOTTEM3X20	20		
FVIOTTEM3X25	25		
FVIOTTEM3X30	30		
FVIOTTEM4X05	M 4 x 5		
FVIOTTEM4X06	6		
FVIOTTEM4X08	8		
FVIOTTEM4X10	10		
FVIOTTEM4X12	12		
FVIOTTEM4X14	14		
FVIOTTEM4X16	16		
FVIOTTEM4X18	18		
FVIOTTEM4X20	20		
FVIOTTEM4X22	22		
FVIOTTEM4X25	25		
FVIOTTEM4X26	26		
FVIOTTEM4X30	30		
FVIOTTEM4X35	35		

Article Code	Measure in mm.	Individual prices	Wrapping price			
FVIOTTEM4X40	40					
FVIOTTEM4X45	45					
FVIOTTEM4X50	50					
FVIOTTEM4X55	55					
FVIOTTEM4X60	60					
FVIOTTEM4X65	65					
FVIOTTEM4X70	70					
FVIOTTEM5X08	M 5 x 8					
FVIOTTEM5X10	10					
FVIOTTEM5X12	12					
FVIOTTEM5X14	14					
FVIOTTEM5X16	16					
FVIOTTEM5X18	18					
FVIOTTEM5X20	20					
FVIOTTEM5X25	25					
FVIOTTEM5X30	30					
FVIOTTEM5X35	35					
FVIOTTEM5X40	40					
FVIOTTEM5X45	45					
FVIOTTEM5X50	50					
FVIOTTEM5X60	60					
FVIOTTEM5X65 *	65					* only on demand
FVIOTTEM5X70	70					
FVIOTTEM6X08	M 6 x 8					
FVIOTTEM6X10	10					
FVIOTTEM6X12	12					
FVIOTTEM6X14	14					
FVIOTTEM6X16	16					
FVIOTTEM6X18	18					
FVIOTTEM6X20	20					
FVIOTTEM6X25	25					
FVIOTTEM6X30	30					
FVIOTTEM6X35	35					
FVIOTTEM6X40	40					
FVIOTTEM6X45	45					
FVIOTTEM6X50	50					
FVIOTTEM6X60	60					
FVIOTTEM6X70	70					
FVIOTTEM6X80 *	80					* only on demand
FVIOTTEM6X90 *	90					
FVIOTTEM8X08 *	M 8 x 8					* only on demand
FVIOTTEM8X10	10					
FVIOTTEM8X12	12					
FVIOTTEM8X14	14					
FVIOTTEM8X16	16					
FVIOTTEM8X18	18					
FVIOTTEM8X20	20					
FVIOTTEM8X25	25					
FVIOTTEM8X30	30					
FVIOTTEM8X35	35					
FVIOTTEM8X40	40					
FVIOTTEM8X45	45					
FVIOTTEM8X50	50					
FVIOTTEM8X55	55					

Article Code	Measure in mm.	Individual prices	Wrapping price			
--------------	----------------	-------------------	----------------	--	--	--

FVIOTTEM8X60	60					
FVIOTTEM8X70	70					
FVIOTTEM8X80	80					
FVIOTTEM10X16	M 10 x 16					
FVIOTTEM10X20	20					
FVIOTTEM10X25	25					
FVIOTTEM10X30	30					
FVIOTTEM10X35	35					
FVIOTTEM10X40	40					
FVIOTTEM10X45	45					
FVIOTTEM10X50	50					
FVIOTTEM10X60	60					
FVIOTTEM10X70	70					

Article Code	Measure in mm.	Individual prices	Wrapping price					
FVIOTTPM3X20	20							
FVIOTTPM3X25	25							
FVIOTTPM3X30	30							
FVIOTTPM3X35	35							
FVIOTTPM3X40	40							
FVIOTTPM4X06	M 4 x 6							
FVIOTTPM4X07	7							
FVIOTTPM4X08	8							
FVIOTTPM4X10	10							
FVIOTTPM4X12	12							
FVIOTTPM4X14	14							
FVIOTTPM4X16	16							
FVIOTTPM4X18	18							
FVIOTTPM4X20	20							
FVIOTTPM4X22 *	22					* only on demand		
FVIOTTPM4X25	25							
FVIOTTPM4X30	30							
FVIOTTPM4X35	35							
FVIOTTPM4X40	40							
FVIOTTPM4X45	45							
FVIOTTPM4X50	50							
FVIOTTPM4X60	60							
FVIOTTPM5X06	M 5 x 6							
FVIOTTPM5X08	8							
FVIOTTPM5X10	10							
FVIOTTPM5X12	12							
FVIOTTPM5X14	14							
FVIOTTPM5X16	16							
FVIOTTPM5X18	18							
FVIOTTPM5X20	20							
FVIOTTPM5X25	25							
FVIOTTPM5X30	30							
FVIOTTPM5X35	35							
FVIOTTPM5X40	40							
FVIOTTPM5X45	45							
FVIOTTPM5X50	50							
FVIOTTPM5X60	60							
FVIOTTPM5X70	70							
FVIOTTPM6X08	M 6 x 8							
FVIOTTPM6X10	10							
FVIOTTPM6X12	12							
FVIOTTPM6X14	14							
FVIOTTPM6X16	16							
FVIOTTPM6X18	18							
FVIOTTPM6X20	20							
FVIOTTPM6X25	25							
FVIOTTPM6X30	30							
FVIOTTPM6X35	35							
FVIOTTPM6X40	40							
FVIOTTPM6X45	45							
FVIOTTPM6X50	50							
FVIOTTPM6X60	60							
FVIOTTPM6X70	70							

Article Code	Measure in mm.	Individual prices	Wrapping price					
FVIOTTGM4X20	20							
FVIOTTGM4X25	25							
FVIOTTGM4X30	30							
FVIOTTGM4X35	35							
FVIOTTGM4X40	40							
FVIOTTGM4X45	45							
FVIOTTGM4X50	50							
FVIOTTGM4X60	60							
FVIOTTGM5X08	M 5 x 8							
FVIOTTGM5X10	10							
FVIOTTGM5X12	12							
FVIOTTGM5X14	14							
FVIOTTGM5X16	16							
FVIOTTGM5X18	18							
FVIOTTGM5X20	20							
FVIOTTGM5X25	25							
FVIOTTGM5X30	30							
FVIOTTGM5X35	35							
FVIOTTGM5X40	40							
FVIOTTGM5X45	45							
FVIOTTGM5X50	50							
FVIOTTGM5X60	60							
FVIOTTGM5X70	70							
FVIOTTGM6X10	M 6 x 10							
FVIOTTGM6X12	12							
FVIOTTGM6X14	14							
FVIOTTGM6X16	16							
FVIOTTGM6X18	18							
FVIOTTGM6X20	20							
FVIOTTGM6X25	25							
FVIOTTGM6X30	30							
FVIOTTGM6X35	35							
FVIOTTGM6X40	40							
FVIOTTGM6X45	45							
FVIOTTGM6X50	50							
FVIOTTGM6X60	60							
FVIOTTGM6X70	70							
FVIOTTGM6X80 *	80						* only on demand	
FVIOTTGM8X14	M 8 x 14							
FVIOTTGM8X16	16							
FVIOTTGM8X18	18							
FVIOTTGM8X20	20							
FVIOTTGM8X25	25							
FVIOTTGM8X30	30							
FVIOTTGM8X35	35							
FVIOTTGM8X40	40							
FVIOTTGM8X45	45							
FVIOTTGM8X50	50							
FVIOTTGM8X60	60							
FVIOTTGM8X70	70							
FVIOTTGM8X80 *	80						* only on demand	
FVIOTTGM8X90 *	90							

S.I.V.E.M. S.n.c.

Società Italiana Viterie E Minuterie

Di Carlo Bisio & C.

Via Milite Ignoto 13/1

16012 Busalla Genova (Italy)

Tel. 010.9640735 Fax. 010.9641996

P.Iva 03621450109

email: cabis@tin.it - sivem.busalla@tin.it

www.sivem.it

