



> DAMPER TYPE MV-PK



- double flange damper is used as a control or shut-off valve intended for operation with air or process gases,
- lamellar sealing suitable for dusty gases,
- possibility of customising face to face length and flange connections,
- standard shaft working position: horizontal (available versions with a shaft positioned vertically),
- leakage rate up to 0.1% Kvs (available with sealing ensuring 100% tightness),
- lightweight shaft version for operation in ventilation systems,
- dampers are used in power generation, chemical, petrochemical, metallurgical, mining, cement, paper and sugar industries.

TECHNICAL DATA

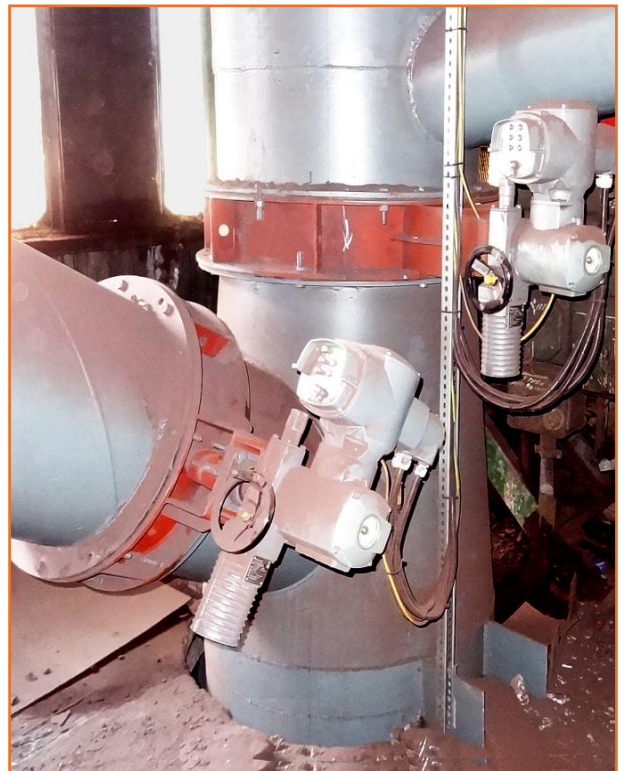
Flange drilling:	PN 2,5, PN 6, PN 10, DIN 24154, DIN 86044 etc. preparation for welded joints or other connections available on special order
Nominal diameter:	DN 200 to DN 3000, intermediate and larger diameters made to special orders
Temperature range:	-40°C to 1100°C (depending on material)
Actuator:	electric, pneumatic, hydraulic, hand actuator
Actuator adaption:	ISO 5211 or customised
Working pressure:	Up to 0,5 bar relative. Versions above 0,5 bar made to special orders

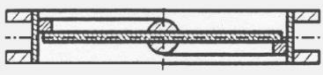

Damper type MV-PK

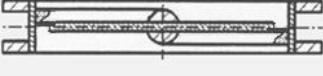
Inside leakage rate			
1		Without landing bar	$\leq 5\%$ Kvs
2		With landing bar	$\leq 0,5\%$ Kvs
3		With landing bar and soft sealing	$\leq 0,1\%$ Kvs
4		With lamellar sealing	$\leq 0,5\%$ Kvs
5		With lamellar sealing and slanted seat	$\leq 0,1\%$ Kvs

Materials:

carbon steel
boiler steel
stainless steel
creep resistant and heat resistant steel
other materials available on special order

Corrosion resistance:

primer paint
zinc plating or hot-dip galvanization
high temperature resistance coating
abrasion resistance coating
etching and passivation (stainless steels)
etc.

Shaft sealing:

graphite
ceramic
Teflon
air sealing system
other sealing types available depending on medium and temperature

We can provide customised solutions meeting special requirements.

Damper type MV-PK

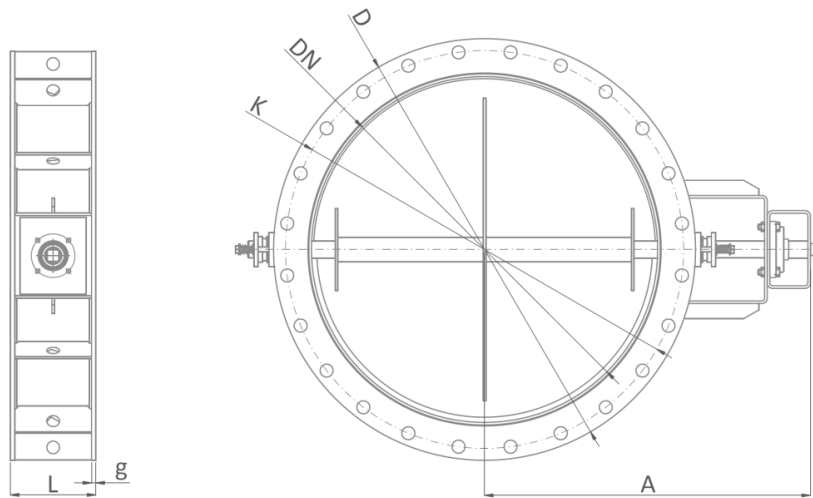

Design dimensions acc. to DIN 86044

DN [mm]	Outside diameter D [mm]	Pitch circle diameter K [mm]	Number of connection holes [pcs]	Diameter of connection hole [mm]	Flange thickness * g [mm]	Length* A [mm]	Face to face* L [mm]
200	320	280	8	18	8	400	160
250	375	335	12	18	8	430	160
300	440	395	12	22	8	460	160
350	490	445	12	22	8	490	160
400	540	495	16	22	8	520	200
450	595	550	16	22	10	540	200
500	645	600	20	22	10	570	200
600	754	700	20	22	10	630	200
700	856	800	24	22	10	680	200
800	958	900	24	22	10	730	200
900	1060	1010	28	22	10	800	200
1000	1162	1110	32	22	12	850	200
1100	1266	1210	32	22	12	900	200
1200	1366	1310	36	22	12	950	200
1300	1466	1410	40	22	14	1000	300
1400	1566	1510	40	22	14	1050	300
1500	1666	1610	44	22	14	1100	300
1600	1766	1710	48	22	14	1160	300
1700	1866	1810	48	22	14	1200	300
1800	1966	1910	52	22	14	1260	300
1900	2066	2010	56	22	14	1330	300
2000	2166	2110	56	22	14	1400	300

* The length can vary depending on medium parameters and process conditions.

The damper design can be suited to individual customer requirements taking into account damper dimensions (diameter, flange drilling, thickness flange and face to face length), mounting arrangements and any other process requirements.

Damper type MV-PK

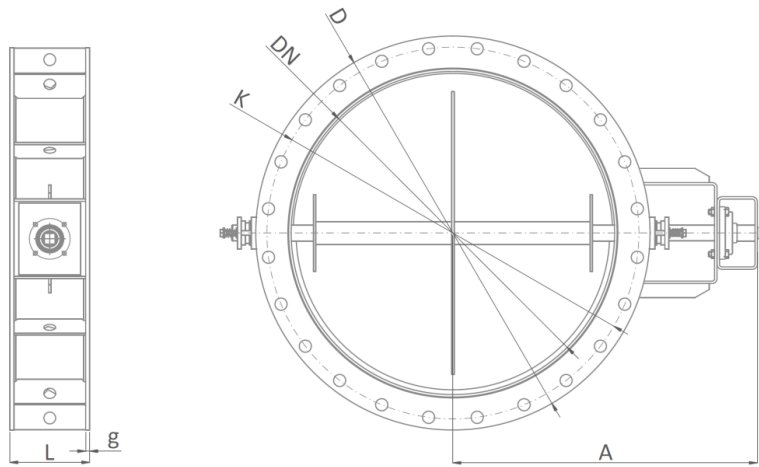

Design dimensions acc. to DIN 24154

DN [mm]	Outside diameter D [mm]	Pitch circle diameter K [mm]	Number of connection holes [pcs]	Diameter of connection hole [mm]	Flange thickness* g [mm]	Length* A [mm]	Face to face* L [mm]
200	273	241	8	11,5	6	400	100
224	297	265	8	11,5	6	420	100
250	323	292	8	11,5	6	430	100
280	363	332	8	11,5	8	450	100
300	383	349	8	11,5	8	460	100
315	398	366	8	11,5	8	460	100
355	438	405	8	11,5	8	490	100
400	484	448	12	11,5	8	520	100
450	534	497	12	11,5	8	540	100
500	584	551	12	11,5	8	570	100
560	664	629	16	14	8	610	100
600	705	665	16	14	8	630	100
630	734	698	16	14	8	660	100
710	814	775	16	14	8	690	100
800	904	861	24	14	8	730	100
900	1004	958	24	14	8	800	100
1000	1105	1067	24	14	8	850	100
1120	1245	1200	32	18	10	920	140
1250	1375	1337	32	18	10	1000	140
1400	1525	1475	32	18	10	1050	140
1600	1725	1675	40	18	10	1160	140
1800	1925	1875	40	18	10	1260	140
2000	2152	2073	40	18	10	1400	140

* The length can vary depending on medium parameters and process conditions.

The damper design can be suited to individual customer requirements taking into account damper dimensions (diameter, flange drilling, thickness flange and face to face length), mounting arrangements and any other process requirements.



Damper type MV-PK Order form

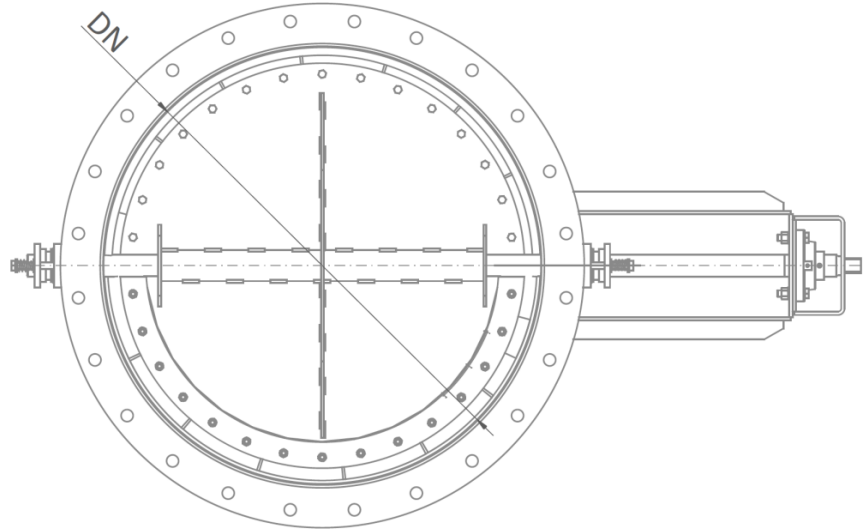

Version*:
Standard / Lightweight

Dimensions:
Nominal diameter DN =
Face to face** L =

Flange drilling*:
PN 2,5 / PN 6 / PN 10 / DIN 24154 / DIN 86044 / other

Type of actuator*:
Manual / Pneumatic / Electric / Hydraulic

Shaft position*:
Horizontal / Vertical

Tightness:
Leakage rate % Kvs

Medium:
.....
.....

Max. working temperature °C
Working pressure bar/kPa*

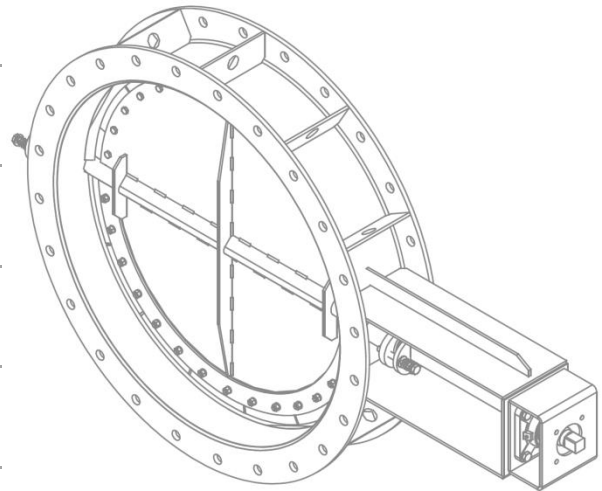

* delete as appropriate
** only in the case of non-standard implementations



multivalve

Multivalve Sp. z o.o.
44-109 Gliwice, ul. Eiffel'a 6
tel. + 48 32 661 00 00
fax: + 48 32 661 00 01
multivalve@multivalve.pl
www.multivalve.pl

TÜV Rheinland certified
ISO 9001 - 2008